

An Ultra-Low Power, Optically-Interrogated Smart Tagging and Identification System

Gerardo Barroeta Perez, Mateusz Malinowski, and Joseph A. Paradiso
Responsive Environments Group
MIT Media Lab
20 Ames St., Cambridge, MA 02139 USA
[jerry_bp, mattxmal,joep]@media.mit.edu

Abstract

We present a wireless identification system that employs an optical communications link between an array of uniquely identifiable smart tags and an interrogator flashlight. As the tags consume a quiescent current of under 2 microamperes and are woken up directly by the interrogator's modulated illumination, they are able to last nearly the shelf life of their battery with moderate use. Unlike RFID, which requires a large antenna to achieve significant range, our system requires only a small photodiode, which enables very compact tags to be rapidly queried at a range of over 8 meters with a handheld flashlight interrogator. Our tags are currently aimed at an asset location scenario, where they pulse an onboard LED when their stored ID matches a query broadcast by the interrogator. We also present two different techniques that allow the tags to talk back to the interrogator – one that uses an onboard IR LED to send data a meter away when the interrogator illumination is off and another that uses the onboard green indicator LED for proximate operation. We present our hardware and system design, analyze its performance, and discuss powering the tag from ambient illumination sources.

1. Introduction

Radio-Frequency Identification (RFID) has become a well-established technology, as passive ID tags exploiting magnetic, electrostatic, and RF coupling have become established as common products [1]. Although RFID tags are well on their way to becoming ubiquitous, they have some characteristics that can inhibit their application in certain niches. For example, the presence of closely proximate metal can interfere with antenna performance, and long-range communications at conventional carrier wavelengths typically involve an antenna that can become quite large. In addition, as the unlicensed bands where

RFID tags operate become more crowded, the tags can become subject to interference.

This paper describes an optically-coupled active ID tag that avoids these difficulties. Our system receives the optical signal with a photodiode of only 1.5 mm diameter, hence the tags can be very small, limited mainly by the size of their associated battery (in this case a 16 mm diameter CR1632 coin cell). Although a battery is required, the tags are woken up from a deep sleep directly by the interrogator's modulated light beam. The very low standby current of these tags (under 2 μ A) can enable their longevity to surpass 7 years, approaching the battery's decade-long shelf life.

This project, a descendant of our original "FindIT Flashlight" system [2], uses a hand-held reader built into a flashlight casing. Although, unlike RFID, an optical line-of-sight is required, the system retains the familiar metaphor of a flashlight, where a user looks for a tagged object by casting the interrogation beam about, just as one hunts for things in the real world. A flashlight can be easily adjusted to seek remote tags within a narrow illumination cone, or, by twisting a lens, generate a wider beam that can locate proximate tags more broadly spaced. Narrow interrogation beams are also more appropriate for applications that require a measure of privacy or security (e.g., identify friend-or-foe operations). Such high directivity and simple beam adjustment are not possible with compact RFID readers at conventional frequencies.

One of the inspirations for our initial work was locating removable storage media that contain specific files. With shrinking form factors limiting available space for scrawling titles at the edges of media cases, we envisioned a solution where an optical interrogator could be programmed with the ID of the volume upon which a file was written – one could then locate this volume on a shelf by scanning the flashlight interrogator across and looking for a tag responding with a flashing LED to indicate a match.

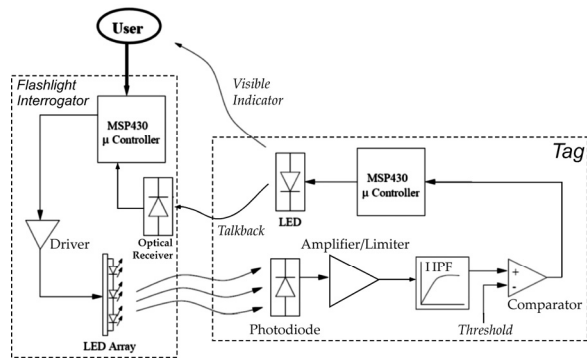

Figure 1: Block diagram of optical tag & interrogator

Passive optical identification tags are, of course, commonplace as barcodes. Although many different barcode protocols have been developed [3], they generally take much more time to read than the active tags described in this article, prohibiting a fast scan across many objects. The read range is also limited for barcodes, e.g., generally well within a meter. Likewise, barcode scanners have to be properly aligned, and barcodes have no possibility of working in a bidirectional fashion, with read-write capability.

Active optical communication [4] is commonplace in items such as remote controls. These data channels run typically at fairly low rates (e.g., hundreds of bits per second), and the active IR receivers that are used require on the order of several milliamps of operating current, which would lead to a much shorter tag lifetime. IRDA communication links, common in laptop computers and cell phones, work at higher data rates, but still tend to consume significant current.

Our original FindIT Flashlight project [2] exploited what we termed “quasipassive wakeup,” where analog signals from the photodiode were conditioned by a passive filter to desensitize the system to ambient light and then detected by a nanowatt comparator, which activated the onboard microcomputer when triggered. Accordingly, as the bulk of the electronics are woken directly from the presence of a modulated optical carrier, the quiescent current of this device is on the order of a half of a microampere, meaning that with a 48mA-h, 3V lithium coin cell, the tag could operate for over 10 years. Assuming that the tag was successfully located 25 times per month, the battery would still last for eight years, as driving the onboard LED to indicate a match draws significantly more current.

The system described in this article improves on our original design in many respects, such as the addition of a micropower amplifier and an improved flashlight interrogator to more than double the read range and inclusion of talkback for bidirectional communication.

A recent project from VTT Electronics in Finland built upon our work with the FindIT Flashlight to

make a IR module that can be retrofit into other equipment to provide a wireless interface with low-power wakeup, although requiring several times higher quiescent current than the circuitry described here [5].

The few tagging systems using optics in commercial development tend to combine RF and light – for example, the Pharmaseq system [6] uses a large array of chemical-sensing RF microtransponders powered by light for bio assays, and the general-purpose passive MM chip from First Hill Electronics [7] is programmed via proximate IR and read via RF.

2. Motivation

Our system’s design goals were inspired by a specific collaboration with one of our industrial partners that runs vast blade server farms. Whenever a server fails or becomes infected with a virus, although the server’s ID is known, it takes a considerable amount of time to physically locate the specific malfunctioning server in the vast racks of hardware. Especially in the case of a virus infection, the server must be quickly removed or deactivated before the virus has a chance to spread. With our optical tagging system, an attendant could quickly locate it using the Flashlight, sweeping the beam past optical tags fixed to the front panel of each blade server. Because of the proximate metal and limited area available, RFID solutions aren’t practical here. This application had several design requirements that had to be met:

Tags must be able to operate on a battery for more than 5 years. This design requirement becomes evident when hundreds of tags are deployed, since it would be cumbersome to change the batteries on the tags every few months. Accordingly, this design requirement was one of the key drivers.

Operation range from the Flashlight to the tag must be at least 3 meters, and the system must be fast enough to pick up the signal even if the flashlight beam is quickly swept past. Many tags must be scanned rapidly, which is facilitated by quickly moving the flashlight when the user is standing a few meters away.

The data rate must support sending a 4-byte binary message sufficiently fast. As mandated by the number of servers installed in a typical farm and the need for fast scans.

The tags must measure roughly 0.5” per side. Since the tags were to be adhered atop IBM Blade Servers, there was not much free panel space to place them.

Tags must be able to store information and talk back. Needed for inventory control or efficient deployment by pointing the flashlight at a unique tag and commanding it to respond with its ID code or enabling codes to be programmed on the fly.

3. Tag and Interrogator Hardware

A block diagram of our system is shown in Figure 1. Our initial designs [2,8] used a modulated defocused laser beam (initially from a 5 mW red laser diode and later a 35 mW IR laser diode) in the flashlight to interrogate the tags. The light coming from the laser would then induce a current in a photodiode on the tag, which in turn would wake up a PIC12LC509A microcontroller from its low power shutdown mode. To avoid the effects of ambient light and low-frequency illumination, the signal from the photodiode was conditioned by a passive RC high-pass filter, and then discriminated by a LTC1540 nanopower comparator with internal voltage reference. This process generates a clean digital gate upon sufficient illumination and eliminates the need for a linear amplifier, which would have consumed much more power (although devices have since improved), something not desirable when using batteries. This produces an interrupt to wake the processor, a process that we term “quasi-passive wakeup” because of the lack of an amplifier stage and the extremely low quiescent current (circa 500 nA).

Once the microcontroller emerges from its sleep mode, the encoded message is compared against a hard coded identification number, specific to each tag. If the code matches, a green LED blinks for a short interval to indicate that the desired tag had been found; otherwise a red LED is lit. The red LED was later eliminated to reduce power consumption.

While this system worked as a proof of concept, it still required further development. The maximum read range was approximately 3m, however the 2 kHz modulation scheme needed roughly 26 ms to transmit a 16-bit code. Additionally, even though the laser beam was defocused to increase the light spot's size, hence loosen requirements on aiming the sensor, the spot diameter was still only on the order of only 2 cm at 3 meters, which made pointing difficult at longer ranges.

Accordingly, the design progressed through a series of refinements. The microcontroller was replaced by a Texas Instruments MSP430F122 with a 100nA typical draw in the deepest sleep mode and an internal RC oscillator, reducing power consumption and physical footprint. The photodiode was also replaced with a smaller, faster device (a Sharp PD100MCOMP), which was back-biased at 3V to improve sensitivity. The comparator stayed the same, however components were changed to accommodate the increased signal speed (from 2kHz to 10kHz), which allowed rapid identification even when the light was quickly passed across a tag.

Since our earlier attempts at using a defocused laser in the interrogator failed at achieving most of the goals for the system (range, scan speed and light spot size), we switched to a high-intensity LED panel containing 20 red LED's, arranged in four rows of 5 LED's each. In normal operation, the panel operates at 12-13 V and consumes between 350-450mA. Since common silicon photodetectors tend to respond more strongly to infrared light, most of the LED's were near-IR, emitting at 845nm, which was well matched to the peak sensitivity of the PD100M. The last LED on each one of the four columns was a visible ultrabright red LED. This was done for two purposes - it gives the user visual feedback, allowing them to easily point the light beam, plus it helped in debugging, making any primary failures in the interrogator obvious.

To increase the operating range and work with broad illumination beams of lower intensity, a Texas Instruments OPA349 operational amplifier was added to the signal chain to provide gain before the comparator, as indicated in Fig. 1. Although it dominates the quiescent power budget of the tag, this amplifier consumes a maximum steady-state current of circa 2 μ A, which doesn't significantly impact battery life for the coin cell that was chosen. As the output current from the photodiode can vary from picoamperes in extremely dim light to hundreds of microamperes in bright illumination and the light intensity coming from the Flashlight could vary widely depending on the distance at which it was placed from the tag, linear photodiode amplifiers exhibited problems in balancing saturation vs. sensitivity. Hence, we needed a robust amplifying scheme that would cleanly condition a signal with flashlight-to-tag distances ranging from zero to three meters. Accordingly, we used a logarithmic amplifier/limiter that would adjust its gain depending on the light received from the Flashlight. Figure 2 shows this circuit – to mitigate the effect of junction capacitance and raise the compression threshold, two transdiodes were placed in series. There are two different operating conditions for this circuit. When the flashlight is far from the tag, the photodiode generates a very weak signal and a large gain is desirable. In this case, the low current coming from the photodiode is not sufficient to generate a voltage high enough to turn on the feedback diodes, so the OpAmp and parasitic characteristics determine a maximum gain. When the flashlight approaches the tag and the diodes start to turn on, the gain drops accordingly, hence the output of the amplifier is clamped at a dual diode drop of roughly 1.2 volts. Accordingly, the amplifier is not allowed to saturate, which degraded the signal quality. This amplifier configuration greatly extended the

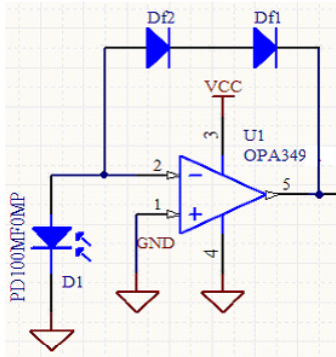

Figure 2: Photodiode amplifier/limiter circuitry

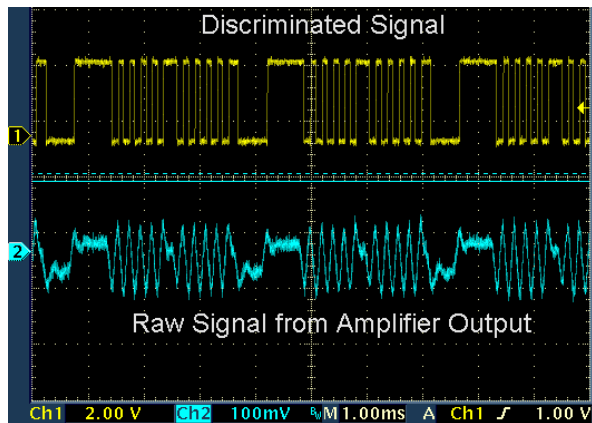

Figure 3: Noisy signal from amplifier (bottom) and recovered serial output from nanopower comparator (top) for the flashlight reader at 5 meter range

operating range of the system, as it is now able to robustly work at up to 8 meters (depending on ambient lightning conditions) which provides more than enough range to meet our goals.

The amplified signals must be discriminated by the nanopower comparator before being sent to the microcomputer. As seen in Fig. 3, the comparator is effective at cleaning up signals received at high range. Since it never saturates from background lighting, the amplifier is DC coupled. The comparator is AC-coupled via a first-order highpass filter that rolls off the response to ambient light and discriminates with respect to the average voltage level, as described in [8]. The digital circuitry is exclusively composed of the microcontroller, which was chosen to be an MSP430F122HBR in a 32-pin QFN package, ideal for an extremely small layout and ultra-low power consumption. The internal Digitally-Controlled Oscillator is used in lieu of an external crystal to keep circuitry and power consumption to a minimum. Also, the internal DCO only takes 6 μ s to start when waking up from the low-power mode instead of milliseconds for crystals. A Texas Instruments TPS3836 voltage

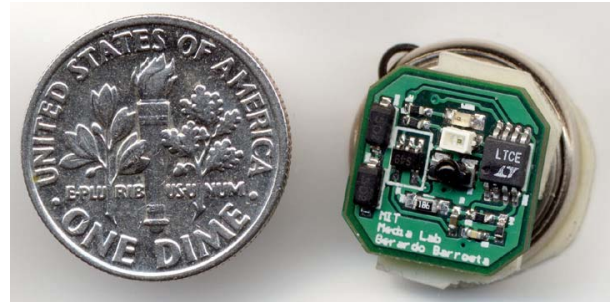

Figure 4: A working optical tag (photodiode in the middle, LED's above), next to a US dime

supervisor was also included to increase supply line robustness. This supervisor consumes less than half a μ A, so the impact it has on power consumption is nearly negligible. A Molex flat cable connector was also included for re-programming the microcontroller.

The microcontroller is configured to run at 1.3 MHz and uses 350 μ A in active mode and 200 nA when waiting for a signal. When receiving a UART start-edge condition from a state change in the discriminated photodiode signal, it wakes up from low-power mode 4 (the deepest sleep mode) and receives the code. Once the microcomputer processes the code, as detailed below, it decides whether or not to answer based on the instruction or the code received. If “find mode” is commanded, the tag just compares the code received to its stored ID, and gives a visual feedback by flashing its onboard green LED for 1 second if there is a match.

Figure 4 shows an actual tag. The circuit card measures 12 mm on each side; hence the package is dominated by the attached battery. For this application a 3V CR1632 Lithium coin cell battery was chosen, which provides 125 mA-h. As the circuit has been measured to consume 1.8 μ A in standby mode, the tags can work for more than 7 years on a single battery. In reality, this lifetime will degrade depending on the quality of the battery and the amount of activation that the tags actually encounter (they take 0.35 mA when the processor runs and 1.25 mA when flashing the LED). If the tag is interrogated several (e.g., over a dozen) times per day, there is still ample charge to surpass our 5-year goal, as illustrated in Figure 5. The lifetime can be improved by paralleling two batteries to increase capacity. In lots of 1000, these tags can be manufactured for less than US \$8, and the price drops quickly with larger quantities.

Figure 6 shows a photograph of our prototype reader/interrogator. As can be seen, it is based on a cannibalized handheld flashlight, with a keypad added to program the transmit code. Tags located within a few meters of the flashlight can be detected within a roughly 90° cone – at 8 meters, this narrows to

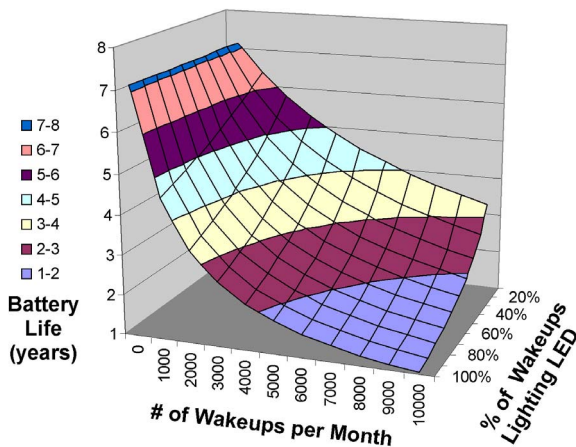

Figure 5: Tag Battery Life as a function of # wakeups and fraction that illuminate LED

approximately 45°. Our current flashlight runs off two 7.4 V, 2.15 A-h Lithium Ion rechargeable batteries, each in a 18 x 65 mm cylindrical package.

4. Communications

Because the amplified photodiode signal is AC coupled to the comparator through the high-pass filter, the encoding scheme must be zero-balanced; i.e., there must be the same number of 0 bits as 1 bits. This is implemented via a biphasic Manchester code [9], where, for every bit of information, the Flashlight transmits two bits (“10” for a logic “1” and “01” for a logic “0”). This effectively halves the data rate available for transmission but still provides 5 Kbps, enough to transmit a 4-byte code in a few milliseconds, which is adequate for operation with fast beam sweeps.

In order to differentiate rotationally equivalent codes, the decoding program needs to synchronize with the beginning of the transmission frame. This is usually done with a unique sequence that does not code for any information and can serve to demark the transmitted command or ID query. Upon recognizing it, the decoding program initializes and begins decoding subsequent data. An additional characteristic of Manchester encoding is that the sequences “00” and “11” are illegal, and do not code for any information. This allows the byte “00 00 11 11” to be used as a unique sequence that bounds the transmission frame and initiates decoding. Finally, this Manchester-encoded data is put into an RS-232 serial-communication wrapper, which allows the processor and tag to send and receive the data directly via the on-chip UART module. This added layer of abstraction increases usability, robustness (the serial port module on MSP430-series processors implements error checking, for example), and access to advanced features, such as “receive-start edge detection,” which



Figure 6: The Flashlight Interrogator/Reader

stores an incoming byte long enough for the processor to wake up from a low-power state and decode it. Upon receiving a character, the tag’s microcontroller verifies that it is the frame boundary. If so, it decodes the following characters in a manner inverse to the procedure described above. Full wakeup of the MSP430 only happens after its UART produces an interrupt upon receiving a valid byte of serial data. Although false transitions can occasionally occur with rapid bright illumination shifts (e.g., room lights going quickly on or off), false wakeups are extremely rare.

A talkback link was added to allow the tags to communicate with the reader. We have implemented this in two ways. One method used an additional IR LED onboard the tag to send Amplitude Shift Keyed (ASK) data at a standard frequency of 38 KHz, which allowed us to use an integrated PNA4613 IR receiver module on the Flashlight. This system supports talkback communication at up to a meter of range and enabled the tags to respond at 1200 bps, which is sufficient to send a test message consisting of a framing byte and six data bytes within 60 ms. Another technique exploits the visible green LED – by modulating it with data at 10 kHz using the Manchester scheme described above, we have been able to talk back to the flashlight over several cm of range. As our uses for talkback involve querying a particular tag and having it send its ID code in response to a blanket command (only executed at installation in our anticipated application scenario), proximate operation should be appropriate here.

Both of these approaches send data back from the tag in the interval between flashlight data packets, where the flashlight’s LED’s are off. Another technique would tightly phase-lock the talkback LED on the tags to the interrogator’s modulation – although the data rate would be somewhat lower, the signal-to-noise (hence range) could be significantly larger.

5. Passive Operation

Although our signal-driven wakeup approach minimizes average current, it is intriguing to think about passive operation, where solar cells can be used to deliver all or part of the power needed to operate the tag. Two modes are relevant, namely when running the microprocessor to check the received code and when flashing the visible LED. As the interrogation beam intensity has been measured at $5 \mu\text{W}/\text{cm}^2$ 1 meter from the interrogator (and drops quadratically with distance), it's not sufficiently powerful to drive the tag on its own. We have found that a 6.5-cm^2 (1-in^2) polycrystalline solar cell can continuously power a flashing tag off a 20 W halogen bulb at 50 cm, implying a very bright interrogator. Power can also be drawn from ambient illumination – standard solar cells are known to produce $10\text{-}100 \mu\text{W}/\text{cm}^2$ in a typically illuminated office [10]. Accordingly, by integrating charge on such a 6.5-cm^2 cell from ambient light, the tags can attain 6-60% duty cycle with LED off and up to 2-20% when flashing. This yields at least 90 minutes of operation per 24-hr day without LED or over 30 minutes with LED, which should be ample, especially as the tags are powered for only a second with the LED and only very briefly when no match is found and the LED stays off.

6. Conclusion and Future Work

We have described and demonstrated a compact (1.6 cm diameter) active micropower optical tagging system that performs at long range (e.g., 8 meters), and have presented two modes of talkback from tag-to-reader that work at shorter range. As the tags take 1.8 μA of quiescent current when waiting for activation, 0.35 μA when briefly activated to check their code, and 1.25 mA when flashing their LED, they should last nearly the shelf life of the battery (e.g., circa 7 years) with over a dozen wakeups per day. This system easily meets the requirements of the blade server locator system introduced in Section 2, and we anticipate field tests to start shortly. The current system sends 3-byte messages from the reader – as the first byte is reserved for framing, we can address an 8-bit ID space w. Manchester Coding. The 5-kbs data rate is sufficiently fast to add additional bytes of ID if needed and maintain rapid enough operation to allow a quick flashlight sweep to detect any matching tags. The tags were seen to behave well – the passive filter and comparator effectively eliminated stray triggering from ambient light and the intrinsic rolloff of the amplifier's gain at high frequency made the system insensitive to modulation from fluorescent lighting. It appears that the tag's current is sufficiently low to

enable a 1 in^2 solar cell to provide sufficient power to run the tag after integrating ambient light over the course of a day, eliminating the need for a battery.

An upgraded flashlight design will explore more convenient form factors, adjustable lenses, and direct USB or wireless connectivity to enable network dialog, plus a new LED panel that integrates 99 ultra-high performance LED's into a single module, potentially enabling significantly higher range.

7. Acknowledgements

We acknowledge our colleagues in the Media Lab's Responsive Environments Group, particularly Hong Ma for early development of the first FindIT Flashlight prototype and Mark Feldmeier and Mat Laibowitz for useful discussions. Mary Murphy-Hoye and her colleagues at Intel Collaboration are particularly thanked for their encouragement and collaboration in tailoring this system for field trials. We appreciate the support of the Things That Think Consortium and the other sponsors of the MIT Media Laboratory.

10. References

- [1] Finkenzeller, K. *RFID Handbook*, New York: John Wiley & Sons, 2003.
- [2] Ma, H. and Paradiso, J.A., "The FindIT Flashlight: Responsive tagging based on optically triggered microprocessor wakeup," in *UbiComp 2002*, G. Borriello and L. Holmquist, Eds. Berlin: Springer-Verlag, 2002, 160-167.
- [3] Palmer, R.C., *The Bar Code Book*, Helmers Publishing; 3rd edition (November 1, 1995).
- [4] Otte, R., de Jong, L.P., and van Roermund, A.H.M., *Low-Power Wireless Infrared Communications*, Dordrecht: Kluwer, 1999.
- [5] Strommer, E. and Suojanen, M., "Micropower IR Tag – A New Technology for Ad-Hoc Interconnections between Hand-Held Terminals and Smart Objects," in the *Proc. of the Smart Objects Conference (sOc 2003)*, Grenoble, France, May 30, 2003.
- [6] Mandrecki, W., "Electronically-indexed solid-phase assay for biomolecules," US Patent 6,686,158, February 3, 2004.
- [7] http://www.fecinc.com.my/products/mmchip/mmchip_index.htm
- [8] Malinowski, M., "Optical Wakeup of Micropower Tags for Object Location and Identification," AUP Undergraduate Thesis, MIT EECS Dept. and Media Lab, May 20, 2004.
- [9] Mills, A., "Manchester encoding using RS232 for Microchip PIC RF applications," Web page, January 2002, http://www.quickbuilder.co.uk/qb/articles/Manchester_encoding_using_RS232.pdf.
- [10] Paradiso, J.A. and Starner, T., "Energy Scavenging for Mobile and Wireless Electronics," *IEEE Pervasive Computing*, Vol. 4, No. 1, February 2005, pp. 18-27.